

Trampoline with Safety Enclosure

USER MANUAL



- 6'(183 cm) Trampoline
- 8'(244 cm) Trampoline
- 10'(305 cm) Trampoline
- 12'(366 cm) Trampoline
- 14'(427 cm) Trampoline
- 16'(487 cm) Trampoline

- 3 Legs*
- 4 Legs*
- 6 Legs*

Spring : 36 48 64 72 88 108

- Optional:
- Basketball hoop
 - 2 step ladder
 - 3 step ladder

READ THIS FIRST!!!

Thank you for purchasing our product

**IN CASE OF MISSING OR BROKEN
PARTS, PLEASE CONTACT PLACE OF
PURCHASE FOR ASSISTANCE.**

Warning: We are not liable for any injuries that may occur when using the trampoline.

GENERAL SAFETY

● INSTRUCTIONS



BEFORE YOU BEGIN USING YOUR BIG TRAMPOLINE: *Read and understand all this information provided to you in this manual.* As with all physical sports and activities there is the risk of participants receiving an injury. To ensure your future enjoyment and the prevention of injury, be sure to follow appropriate safety rules and tips.

- ALWAYS CONSULT A DOCTOR/PHYSICIAN BEFORE PERFORMING ANY KIND OF PHYSICAL ACTIVITY.
- ALWAYS CHECK YOUR BIG TRAMPOLINE BEFORE USE, PAYING SPECIFIC ATTENTION TO ALL THE BOLTS, JUMP MAT AND PADS POSITION. DON'T USE IF ANY PARTS ARE MISSING OR LOOK LIKE THEY SHOW WEAR AND TEAR.
- ALWAYS USES THE PROVIDED SAFETY ENCLOSURE WHEN USING THE TRAMPOLINE.
- ALWAYS ENSURE THAT THE TRAMPOLINE IS USED BY ONLY ONE PERSON AT A TIME.
- ALWAYS ENSURE THAT WHENEVER THE TRAMPOLINE IS USED BY ANYONE AT ANY SKILL LEVEL THAT DO SO UNDER SUPERVISION.
- Stop exercising immediately should you feel unwell or if you feel pain in your joints and muscles. Dizziness is a sign of fatigue and you should stop bouncing and lay down on the ground should you feel dizzy.
- When using this trampoline ensure appropriate clothing is worn, preferably sports wear and socks .NEVER WEAR SHOES ON THE MAT.
- Please be warned that trampoline is spring based and will allow the user to jump to a greater height than that on the ground, so please bear this in mind and ensure that you are comfortable bouncing at low heights first.
- Proper assembly, care and maintenance of product, safety tips, warnings, and proper techniques for jumping on your trampoline are included in this manual for your safety and an extended product life span. All users and supervisors should therefore familiarize themselves with these instructions. Anybody who chooses to use the trampoline must be aware of their own limitations with regards to performing skills on this trampoline.
- The safety enclosure is there to prevent the user falling off the trampoline, and is not to be jumped into unnecessarily.
- Trampoline should be assembled on grass or BSI approved safety matting.

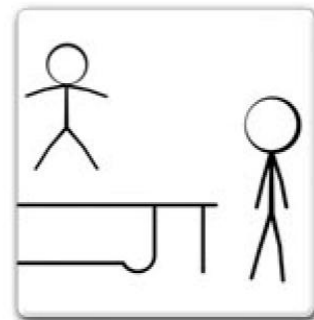
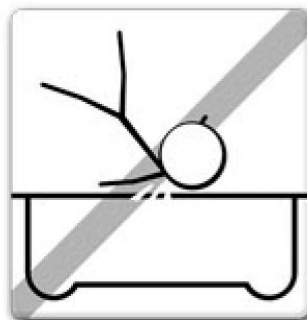

INFORMATION ON THE

● USE OF TRAMPOLINE

INITIALLY, you should get accustomed to your trampoline and understand how much spring is in each bounce .The focus at this point should be body position and technique until each skill can be completed with ease and control.

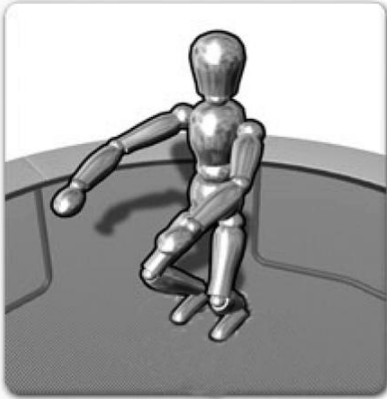

- **BEFORE YOU TRY TO JUMP TOO HIGH** the technique for stopping should be learnt as this will help prevent injury should you feel you are jumping out of control.
- As the user lands on the bed knees should be bent so that they stop and absorb the spring in the mat.The position is shown in the image to the left. Arms are held out for increased level of balance.
- **This skill is used when the trampoline user wishes to stop bouncing on the trampoline due to fatigue, loss of control, etc.**



SOMERSAULTS (FLIPS): DO NOT PERFORM somersaults of any type (backwards or forwards)on this trampoline.If you make a mistake when trying to perform a somersault ,you could land on your head or neck .This will increase your chances of your neck or back being broken ,which could result in death or paralysis



FOREIGN OBJECTS : DO NOT use the trampoline if there are pets ,other people ,or any objects underneath the trampoline .This will increase the chances of an injury occurring ,**DO NOT** hold any foreign objects in your hand and **DO NOT** place any objects on the trampoline while in use. **DO NOT** place the trampoline under over-hanging objects like tree branches, wires, etc as these will increase your chances of being injured.



POOR MAINTENANCE OF TRAMPOLINE: A trampoline in poor condition will increase your risk of being injured. Please inspect the trampoline before each use for bent steel tubes, torn mat, loose or broken springs and overall stability of the trampoline.



WEATHER CONDITIONS: Please be aware of the weather conditions when using the trampoline. If the mat of the trampoline is wet, the user could slip and injure himself /herself .If it is too windy, the user could lose control.



RESTRICTING ACCESS: When the trampoline is not in use, always store the access ladder in a secure place so that unsupervised children can not play on the trampoline.

TIPS TO REDUCE THE

● **RISK OF ACCIDENTS**

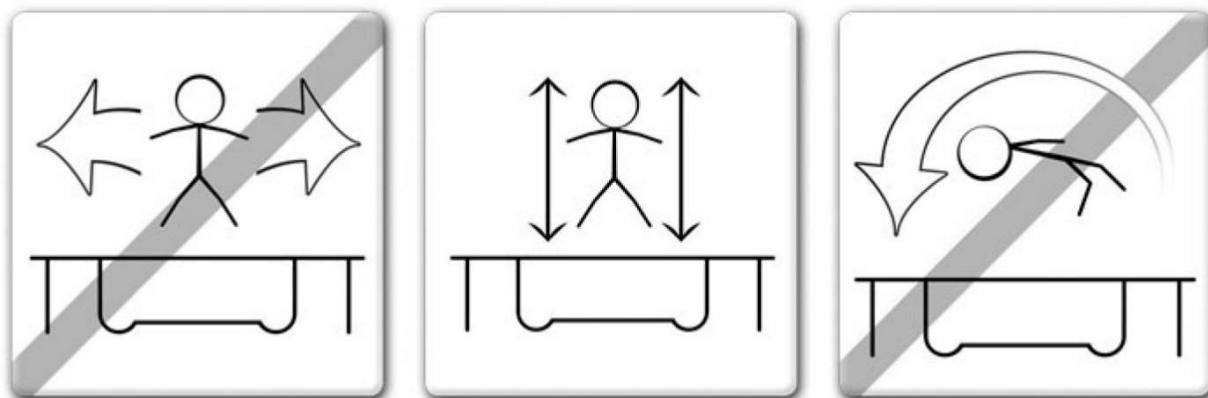

In order to reduce the risk of accident the "TRAMPOLINE USER" should:

- Always remain in control of their jumps and body position at all times.
- Not attempt to perform skills that are beyond their own level of competence.
- Read and understand the jump by taking off and landing in the middle of the trampoline.
- Always control their jump by taking off and landing in the middle of the trampoline.
- Always jump vertically and refrain from bouncing towards the springs in any direction.
- Always consult a professionally certified trampoline instructor before attempting anything beyond basic techniques.

In order to reduce the risk of accident the "SUPERVISOR" should:

- Fully understand and enforce all the safety rules and guidelines.
- Advise the trampoline user and provide knowledge in what they are doing right and wrong to ensure the safety of trampoline user.
- Be aware and advise the trampoline user of all the safety warnings.

IMPORTANT: If the Trampoline can not be supervised there should be a method for securing it and preventing anyone from using the product until supervision is available.

TRAMPOLINE

● SAFETY INSTRUCTIONS

ADVISORY PRECAUTIONS WHILST USING THE TRAMPOLINE

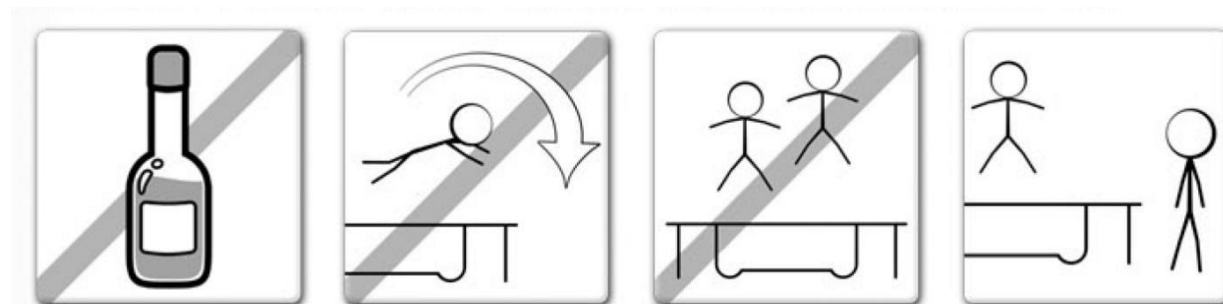

- Do not use trampoline if you have consumed alcohol or narcotic substances
- You should climb on and off the trampoline in a controlled and careful manner. Never jump onto or off the trampoline and never use the trampoline as a means to bounce onto or into another object.
- Always learn the basic bounce and master each type of bounce before trying more difficult types of bounces .Review the basic skills section to learn how to do the basics.
- To stop your bounce, flex your knees when you land on your feet.
- Always be in control when you are bouncing on the trampoline. A controlled jump is when you land at the same spot that you took off from. If at any time you feel out of control, stop bouncing immediately.
- Do not jump or bounce for prolonged periods of time or too high for a number of jumps. Keep your eyes on the mat to maintain control. If you do not, you could lose your balance.
- Never have more than 1 person on the trampoline at any one time.

ADVISORY PRECAUTIONS WHILST SUPERVISING TRAMPOLINE

IMPORTANT: Familiarise yourself with the basic jumps and safety rules .To prevent and reduce the risk of injuries, ensure that all safety rules are enforced and the new users learn the basic bounces before trying more advanced techniques .

- **ALL USERS need to be supervised, regardless of skill level or age.**
- Never use the trampoline when it is wet, damaged, dirty or worn out. The trampoline should be inspected before use.
- Keep all objects that could interfere during use away from the trampoline at all times. Be aware of what is overhead, underneath and around the trampoline.
- To prevent unsupervised and unauthorized use, the trampoline should be secured at all time.

ACCIDENT

● CLASSIFICATION & IDENTIFICATION



MOUNTING AND DISMOUNTING:

Be very careful when getting on and off the trampoline. **DO NOT** mount the trampoline by grabbing the frame pad, stepping onto the springs or by jumping onto the mat of the trampoline from an object(eg. A deck, roof ,or ladder).This is considered highly dangerous. **DO NOT** dismount by jumping off the trampoline and landing on the ground. If small children are playing on the trampoline, they may need help in mounting and dismounting.



USE OF ALCOHOL OR DRUGS:

DO NOT consume any alcohol or take any drugs (*this includes medication that could affect the users co-ordination*) when using this trampoline. This is considered highly dangerous since these foreign substances impair your judgements, reaction time and overall physical co-ordination.



MULTIPLE USERS:

If you have multiple users (more than one person on the trampoline at any one time), you increase the chance of being injured. Injuries can occur when you fly off the trampoline, lose control, collide with other jumper(s), or land on the springs .



STRIKING THE SPRING FRAME:

When playing on the trampoline, **STAY** in the centre of the trampoline mat. This will reduce the risk of being injured by landing on the spring frame. Always keep the frame pads covering the frame of the trampoline. **DO NOT** jump or step onto the frame pad directly since it is not intended to support the weight of a person.



LOSS OF CONTROL:

DO NOT try difficult manoeuvres until you have mastered the basics. If you do not follow these guidelines, you increase the risk of someone being injured.

TRAMPOLINE TECHNIQUES

● BASIC SKILLS

BASIC SKILL 1: The Basic Bounce

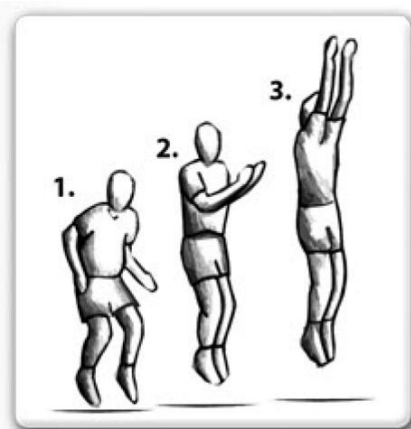

- Start from a standing position, with feet shoulder width apart head up and eyes on the trampoline bed.
- Swing arms forward and up above head in a circular motion.
- Bring legs and feet together in " mid-air " position and point toes.
- Land back on the mat with feet shoulder width apart (same as start position).
- Why not try moving onto the next skill once comfortable and proficient.

BASIC SKILL 2: The Knee Drop

- Start with a low basic bounce (as detailed in BASIC SKILL 1).
- Land on knees shoulder width apart, keeping back straight and a strong body position using arms out to the side or in front to maintain balance.
- Bounce back to basic bounce position by using bounce momentum and swinging arms above head.
- Once mastered at this height try bouncing a little higher, but remember to always stay in control of your height.



BASIC SKILL 3: The Seat Drop



- Start with a low basic bounce (BASIC SKILL 1) in the normal
- Land with legs out straight in front of you, with hands either side of your hips and back straight in a strong body position.
- Use the bounce momentum aided with a push from hands to return to a standing position.
- Once mastered at this height try bouncing a little higher, but remember to always stay in control of your height.

IMPORTANT: Please consult a trained trampoline instructor before attempting any more advanced skills to ensure highest possible safety levels are maintained.

TRAMPOLINE TECHNIQUES

● **ADVANCED SKILLS**

ADVANCED SKILL 1: The Basic Bounce



- Start with a low basic bounce (BASIC SKILL1) in the normal position.
- Land on your hands and knees at the same time, ensure that back is horizontal to the bounce mat and hands & legs are shoulder width apart also.
- Use the momentum of bounce and push off hands to regain the standing position.
- Once mastered at this height try bouncing a little higher, but remember to always stay in control of your height.
- Try moving onto the next skill once comfortable and proficient.

ADVANCED SKILL 2: Hands and Knees to Front Drop

- Land on your hands and knees at the same time, ensure the back is horizontal to the bounce mat and hands & legs are shoulder width apart also.
- Maintain strong body position with back horizontal to mat and straighten legs behind and fold arms in front of face in mid-air ready to land on the mat in a lying down position.
- Ensure the landing is done with all of body touching the mat at same time.
- Push off hands and recover the standing position.
- Once mastered at this height try bouncing a little higher, but remember to always stay in control of your height .Trying moving onto the next skill once comfortable and proficient.

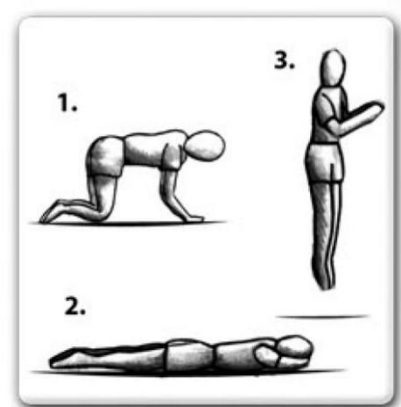

ADVANCE SKILL 3: The Front Drop

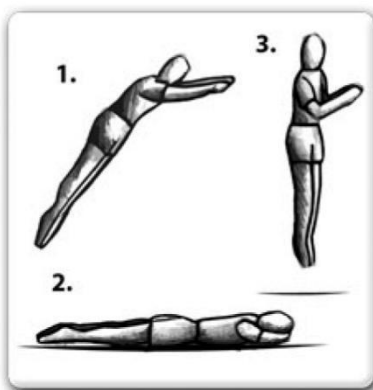

- Start with a low basic bounce (BASIC SKILL 1) in the normal position.
- Maintain strong body position with back horizontal to mat and straighten legs behind and fold arms in front of face in mid-air ready to land on the mat in a lying down position.
- Ensure the landing is done with all of body touching the mat at the same time.
- Push off hands and recover the standing position.
- Once mastered at this height try bouncing a little higher, but remember to always stay in control of your height.

IMPORTANT: Should you wish to progress any further and learn more advanced techniques for trampoline, please consult a qualified and registered instructor.

TRAMPOLINE ASSEMBLY WARNINGS

Please read these assembly instructions before starting assembly trampoline. Improper assembly can damage the trampoline frame.

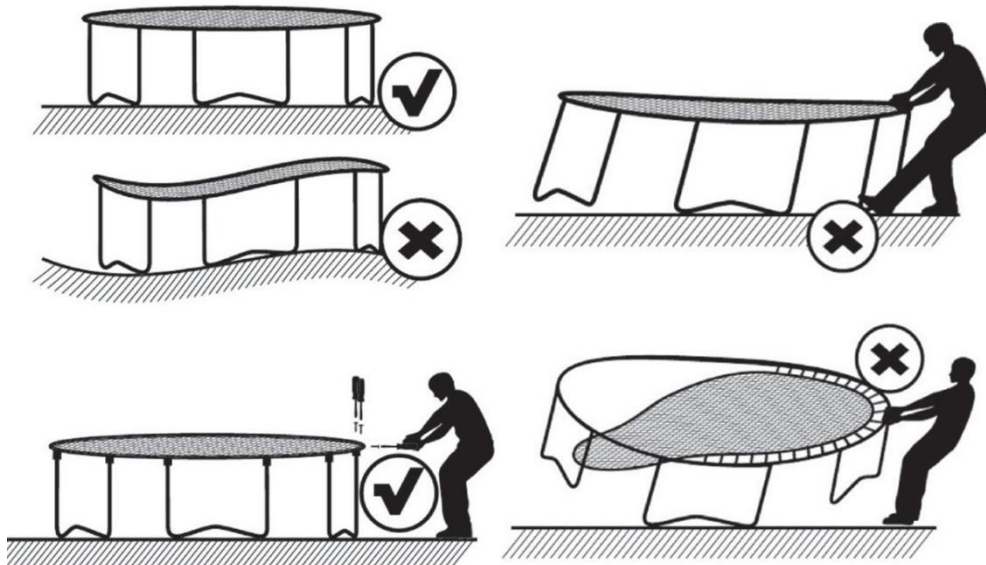

- Make sure the trampoline is placed on a level ground. Uneven floor surfaces they can cause the trampoline frame to warp.
- Make sure that all bolts holding the frame joints are fully tightened before installing the springs. If you don't tighten properly, the frame will deform.
- Make sure you DO NOT use one leg to push against the leg or frame of the trampoline when loading the springs. It will cause the trampoline to deform.
- DO NOT load the springs into the frame on only one side of the trampoline. The uneven distribution of stress on the springs will cause the frame to warp.
- If the trampoline frame deforms, don't be alarmed anymore that the system is designed to be a bit flexible.

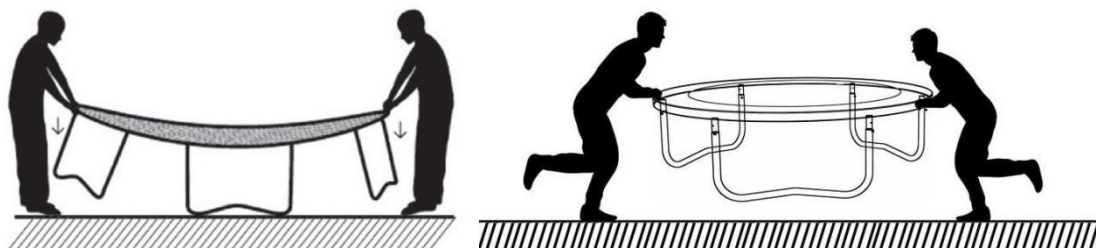

- Push down the part of the frame that deformed with two people as shown. The frame will level out.
- If the trampoline and enclosure need to be moved, at least two people should move it, keep it horizontal, and lift it slightly. If necessary, the trampoline can be taken to move. To remove the trampoline, follow the assembly steps in reverse order.
- If you need to move the trampoline, at least two people must be used. All connection points should be wrapped securely with weather resistant tape, such as duct tape. This will keep the frame intact during movement and prevent the connector points from dislodging and separating. When moving, lift the trampoline slightly off the ground and keep it horizontal to the ground. For any other type of movement, you must disassemble the trampoline.

TRAMPOLINE ASSEMBLY

- **STEP BY STEP CONSTRUCTION**
- **Only assemble by adult.**

To assemble this trampoline all you need is our special spring loading tool provided with this product.

During periods of non-use. This trampoline can be easily disassembled and stored.

Please read the assembly instructions before beginning to assemble the product.

Please refer to the table for part descriptions and numbers. The assembly instruction use these descriptions and numbers as reference .

Make sure you have all parts listed. If you are missing any parts, please contact place of purchase.

Please use gloves to protect your hands from pinch points during assembly. When you are ready to start, make sure that you have plenty of space and a clean dry area for assembly.

TRAMPOLINE PARTS LIST

Ref. Number	Description	Unit	6'	8'	10'	12'	14'	16'
1	Trampoline Mat, stitched with V-Rings	Pcs	1	1	1	1	1	1
2	Frame Pad	Pcs	1	1	1	1	1	1
3	Top Rail	Pcs	6	6	8	8	8	12
4	Leg Base	Pcs	3	3	4	4	4	6
5	Vertical Leg Extension	Pcs	0	6	8	8	8	12
6	Springs	Pcs	36	48	64	72	88	108
7	User manual	Pcs	1	1	1	1	1	1
8	spring tool	Pcs	1	1	1	1	1	1
9	screw of legs	Pcs	6	6	8	8	8	12
10	T Connector	Pcs	6	6	8	8	8	12
11	Spanner	Pcs	1	1	1	1	1	1

Enclosed are the current specifications and product features available at time of printing, however, changes may be made in equipment, availability, specifications and features without notice.

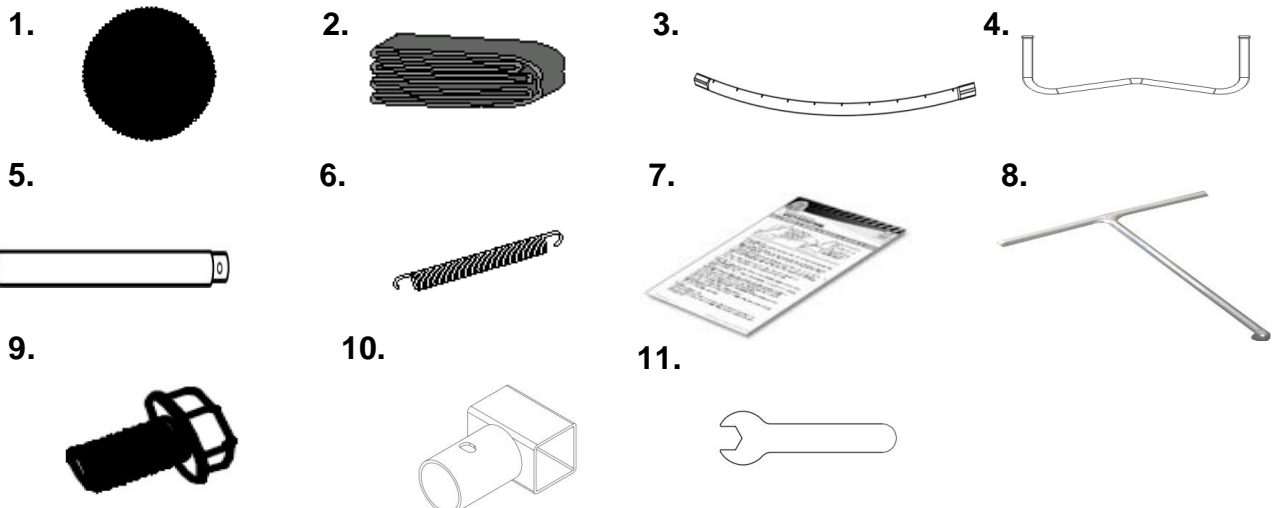



Frame layout

Please use the parts list table on other page to identify and layout all the parts as pictures, select which size trampoline you have purchased first, then refer to the following pictures.

All the “ Top rail with T connector ”, are universal parts and can only go together in one way.

To connect the parts, simply slide the thinner end of the tubing into the adjacent section with the larger opening.

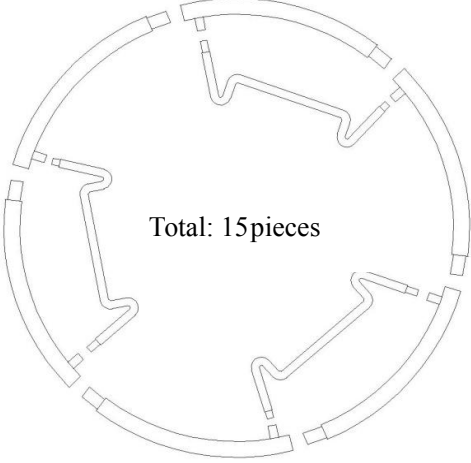
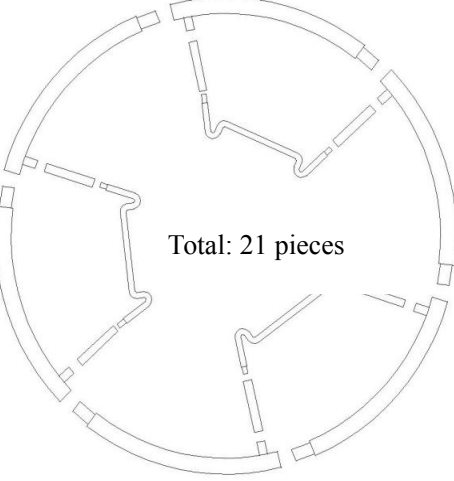
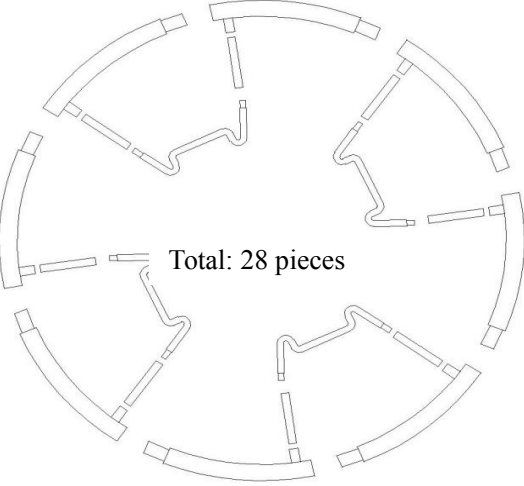
These joints are called “ connector points”.

<p>➤ 6' Trampoline (3 Legs)</p>  <p>Total: 15 pieces</p>	<p>➤ 8' Trampoline (3 Legs)</p>  <p>Total: 21 pieces</p>
<p>➤ 10',12',14' Trampolines (4 Legs)</p>  <p>Total: 28 pieces</p>	<p>➤ 16' Trampoline (6 Legs)</p>  <p>Total: 42 pieces</p>

STEP 1 -Top Rail Assembly

Two people will be necessary at this point to assemble the trampoline. All the top rails should be connected by connectors

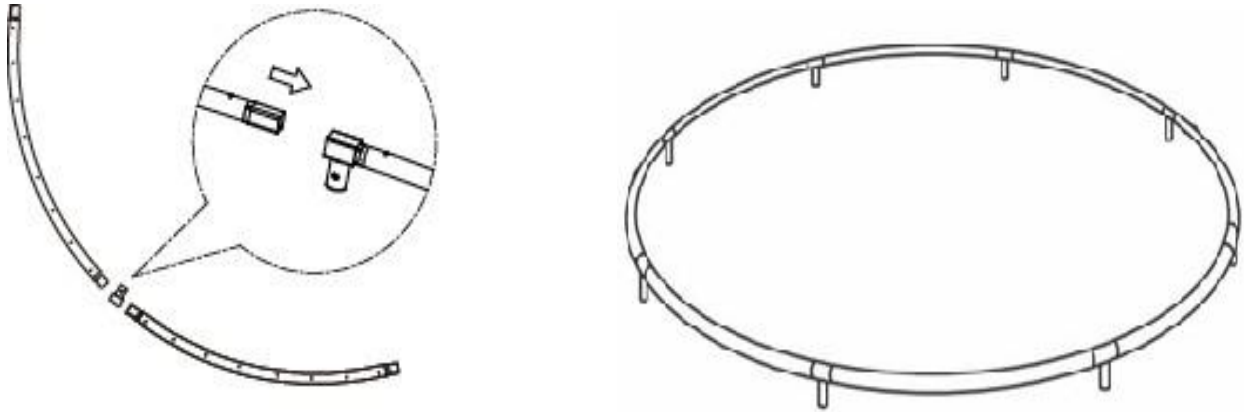

STEP 2-Support Assembly

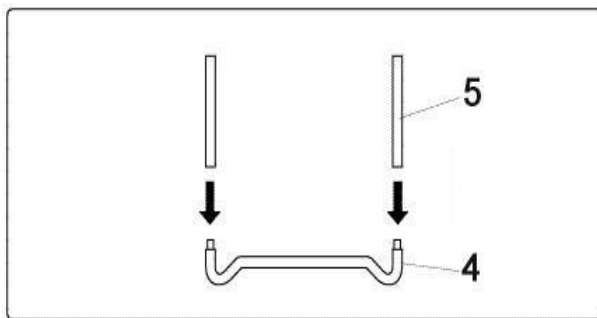

Slide all Vertical Leg Extensions(5) into Base(4).

Then two people set up all the tubes the same to Fig 5, 6

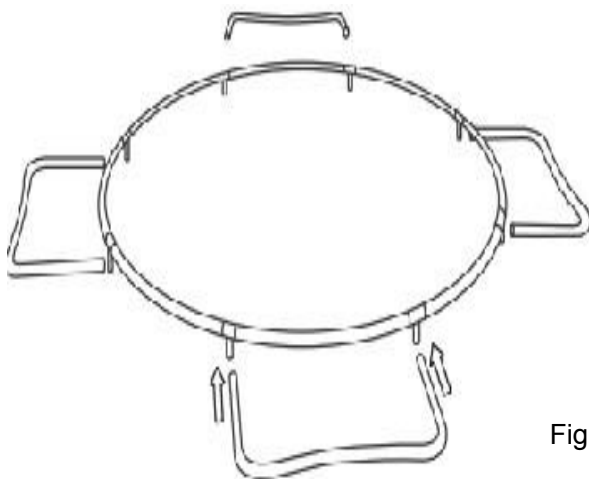

Fig. 5

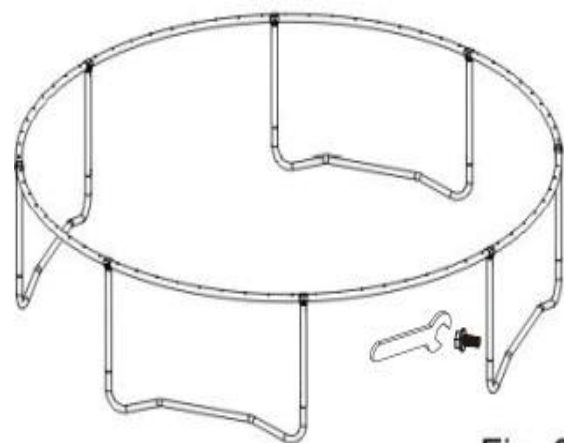
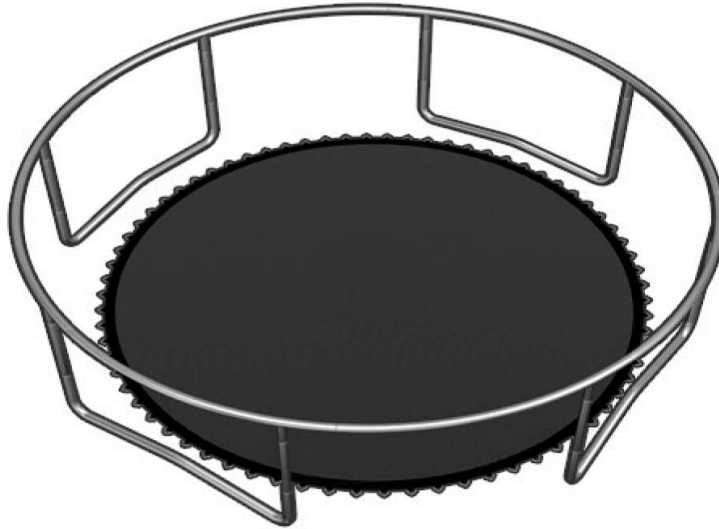

Fig. 6

STEP 3: - Trampoline Mat Assembly

WRNING: Attaching springs, the connector points can become pinch points since the trampoline is tightening up. With this in mind please be careful attaching springs to the trampoline mat. Please be careful. You will need at least one person to help with this portion of assembly.



Layout the “**Trampoline Mat**” inside the frame on the floor as picture above

STEP4: ATTACHING THE SPRINGS TO TRAMPOLINE MAT

The springs need to be placed in position as shown in the diagram to the right, in order to pull the " Trampoline Mat " in all four directions (Fig 1), then in eight directions (Fig.2) and repeat.

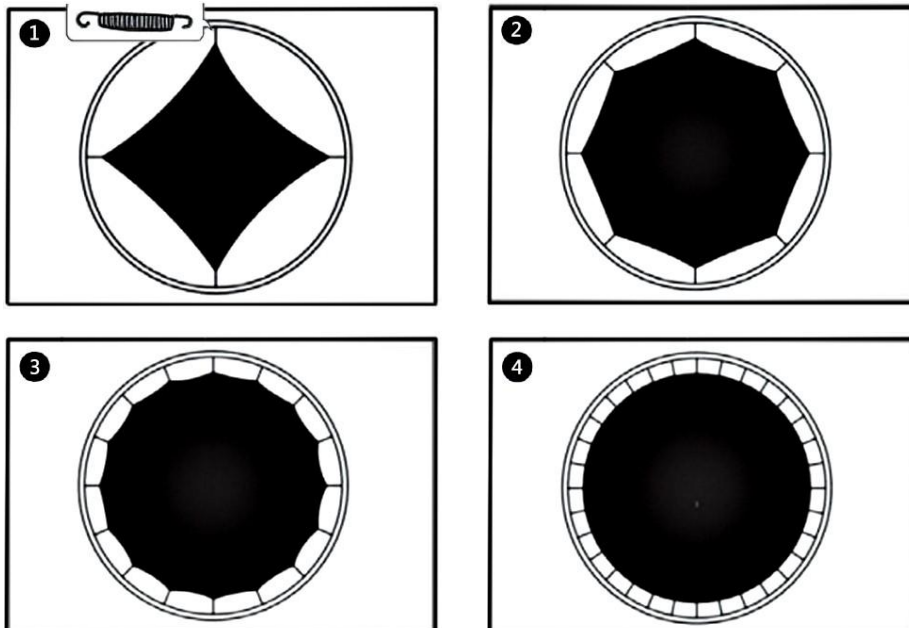

HOW TO USE THE " SPRING LOADING TOOL "

Firstly hang one side of spring on the triangle attached to the " Trampoline Mat " ,and use the " spring tool "to hook the other side of spring (As shown in the top image to the right) .

Pull the " Spring Tool " until the spring hook insert the hole on the "trampoline frame" and disengage the " Spring Tool " leaving the " Spring " in place. Repeat process for all springs .

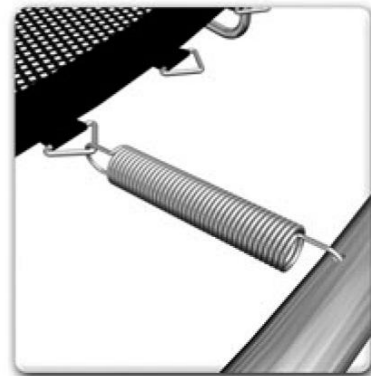
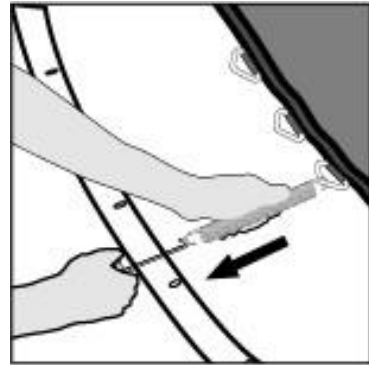

WARNING!! : Please be careful where your hands and other parts of the body are placed as the connector points and spring attachments can create hand or body traps.

STEP 5-Frame Pad Assembly

A. Lay the Frame Pad over the trampoline so that the springs and the steel frame is covered.

Please ensure that the Frame Pad covers all metal parts.

B. Tie the strap located at the under side of the frame pad to the frame.

C. Select your Pad model.

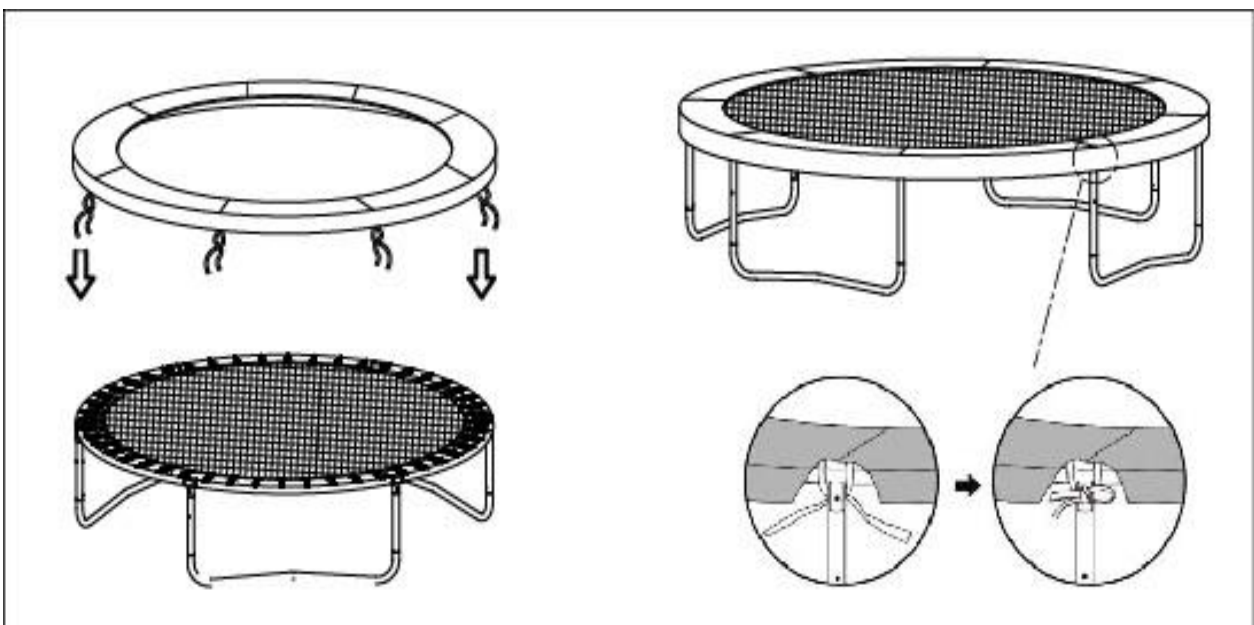

CARE AND MAINTENANCE

This trampoline was designed and manufactured with quality materials and craftsmanship. If proper care and maintenance is provided, it will provide all jumpers with years of exercise, fun, and enjoyment as well as reduce the risk of injury. Please follow the guidelines listed below:

This trampoline is designed to withhold a certain amount of weight and use. Please make sure that only one person at any one time uses the trampoline. Also, the person should weigh less than 333 pounds (150kgs). Jumpers should either wear socks, gymnastics shoes, or be barefoot when using the trampoline. Please be aware that street shoes or tennis shoes should NOT be worn while using the trampoline. In order to prevent the trampoline mat from getting cut or damaged please do not allow any pets onto the mat. Also, jumpers should remove all sharp objects from their person prior to using the trampoline. Any type of sharp or pointed objects should be kept off the trampoline mat at all times.

Always inspect the trampoline before each use for worn, abused or missing parts. A number of conditions could arise that may increase your chances of getting injured. Please be aware of:

- Punctures, holes, or tears in the trampoline mat
- Sagging trampoline mat
- Loose stitching or any kind of deterioration of the mat
- Bent or broken frame parts, such as the legs
- Broken, missing, or damaged springs
- Damaged, missing, or insecurely attached frame pad
- Protrusions of any types (especially sharp types) on the frame, springs, or mat

IF YOU FIND ANY OF THE PREVIOUS CONDITIONS, OR ANYTHING ELSE THAT YOU FEEL COULD CAUSE HARM TO ANY USER, THE TRAMPOLINE SHOULD BE DISASSEMBLED OR SECURED FROM USE UNTIL THE CONDITION(S) HAS BEEN RESOLVED.

WINDY CONDITIONS

In severe wind situations, the trampoline can be blown about. If you expect windy weather conditions, the trampoline should be moved to a sheltered area or disassembled. Another option is to tie the round, outside portion (top frame) of the trampoline to the ground using ropes and stakes. To ensure security, at least three (3) tie downs should be used. Do not just secure the legs of the trampoline to the ground because they can pull out the frame sockets.

MOVING THE TRAMPOLINE

If you need to move the trampoline, two people should be used. All connector points should be wrapped secured with weather resistant tape, such as duct tape. This will keep the frame intact during the move and prevent the connector points from dislocating and separating. When moving, lift the trampoline slightly off the ground and keep it horizontal to the ground. For any type of other move, you should disassemble the trampoline.

ASSEMBLY INSTRUCTION FOR PROTECTIVE NET

1. Parts List

Reference Number	Description	6/8/10'	10/12/13/14'	16'
1	Upper pole A	6pcs	8pcs	12pcs
2	Upper pole B	6pcs	8pcs	12pcs
3	Bolt Pack	12pcs	16pcs	24pcs
4	Pole Cover (optional)	6pcs	8pcs	12pcs
5	Safety Net	1pc	1pc	1pc

2. Diagram for Parts



3. Bolt Pack



4. Pole cover

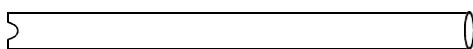

5. Safety Net

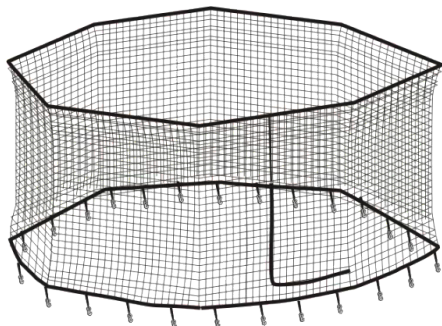

WARNING: READ AND FOLLOW THIS INSTRUCTION, PRIOR TO ASSEMBLE AND USE OF THIS EQUIPMENT.

3. Assembly Instruction

WARNING: Two adults in good physical condition are required for the following assembly. For your safety, you should wear proper shoes and clothing, Failure to follow these instructions and warning may result in injury.

STEP 1: Connect two sections of upper poles together as shown in Figure1

Wear the pole cover on the assembled poles as shown in Figure 2

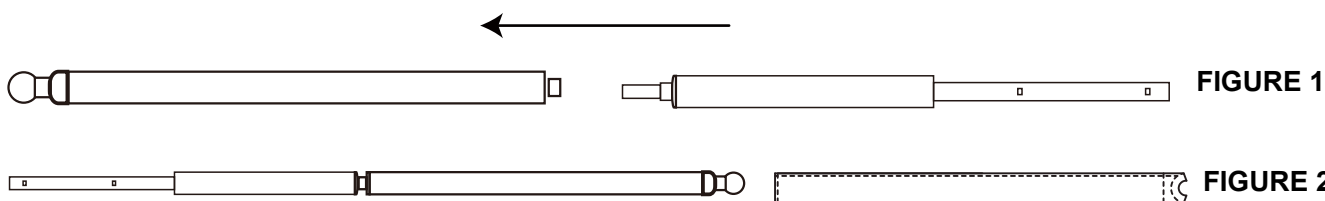

STEP 2: Repeat step1 until all the assembled poles set up. please see pictures in below.

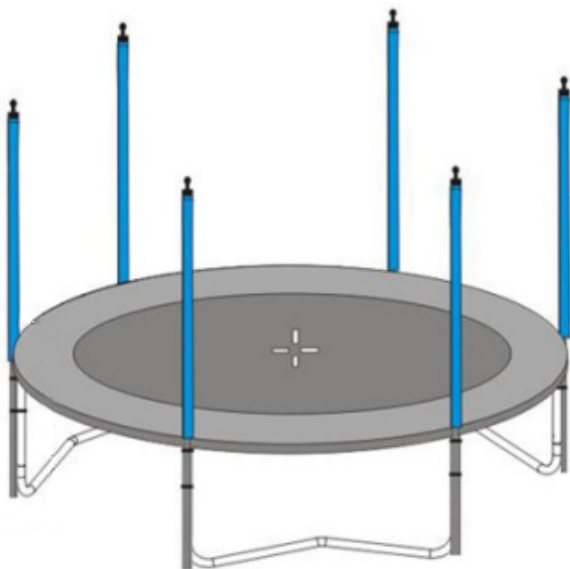

A1: Mount the upper poles onto the vertical tubes.

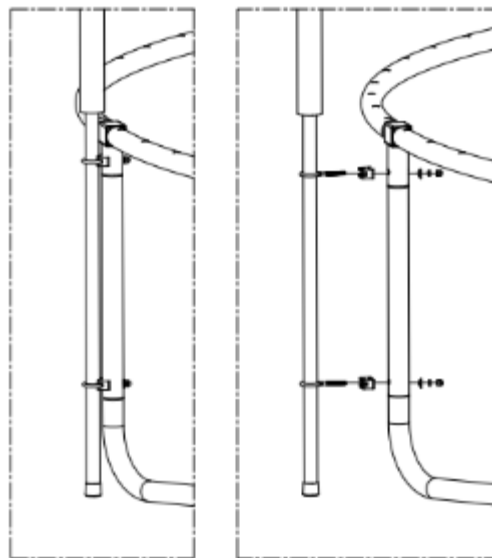

A2: Tighten the screws.

STEP 3: Spread safety net (#5) out on the trampoline mat. Locate the panel with the doorway and align the net as to where you would like to get in and out of the trampoline. The edge with the pre-sewn hanging loop on the upper part of the net will be hooked at the top of the pole. (See B)

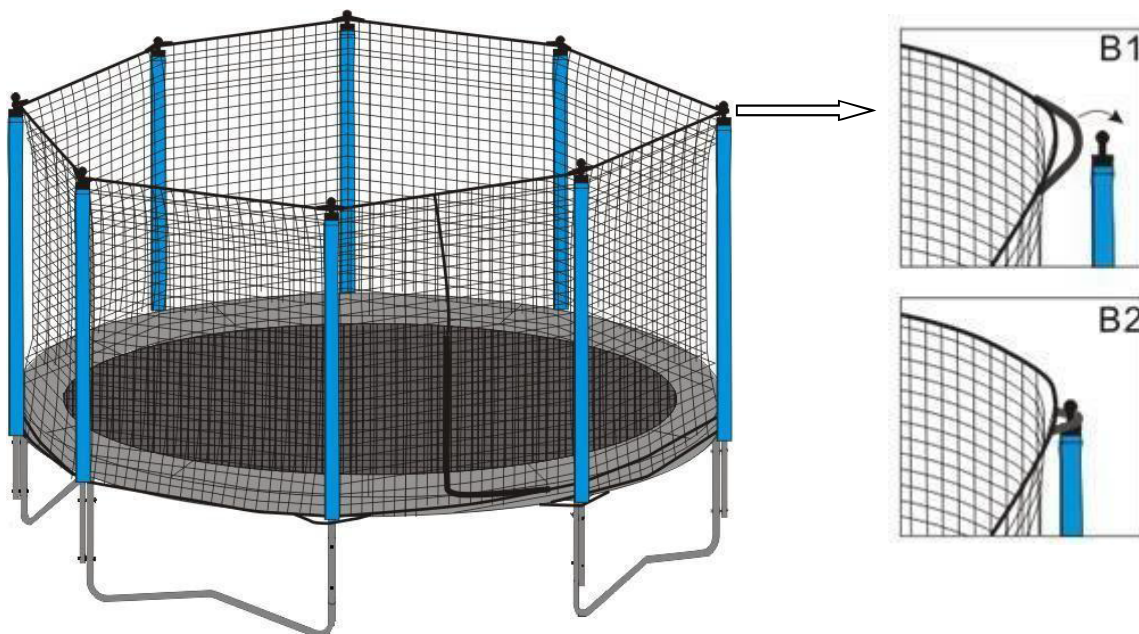

STEP 4:

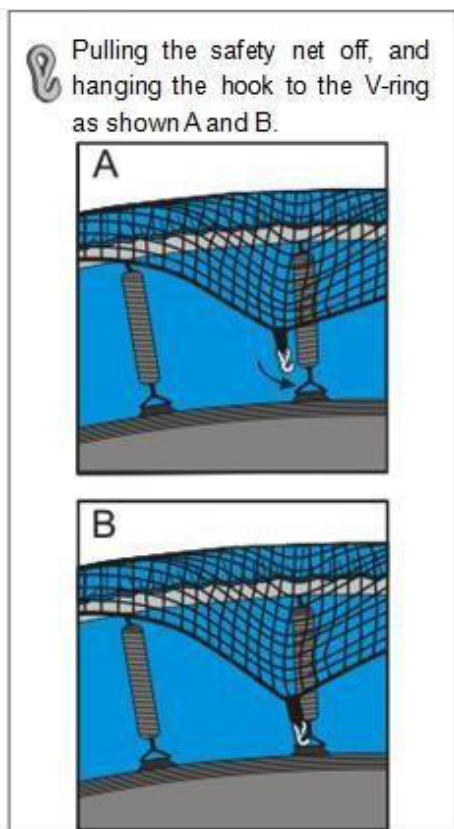

Warning Tip:
 Pls hang the hooks from door first,
 Pls cross the hook as below.

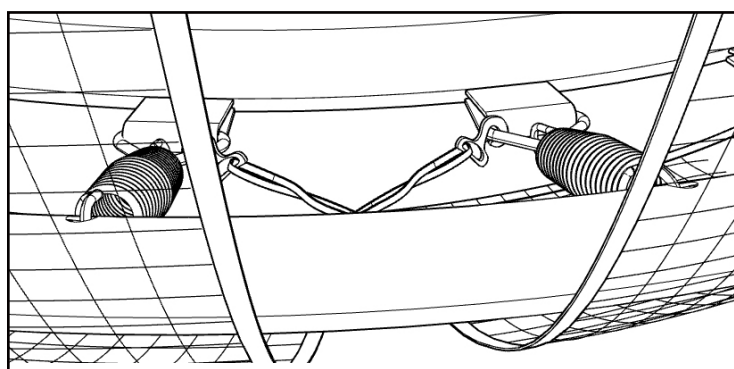

STEP 5: HOOK TO THE V-RING AS ORDER AS **FIGURE 6**

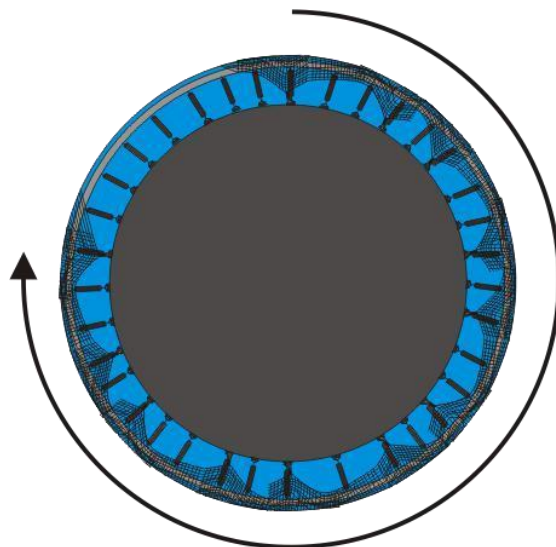

FIGURE 6

STEP 6: WHEN YOU SET UP AS SAME AS **FIGURE 7**. YOU NEED MORE FORCE TO PULL DOWN THE NET(MAYBE NEED TWO ADULTS HELP). SO THE NET WILL VERY TIGHT FOR TRAMPOLINE.



FIGURE 7

! IMPORTANT WARNING!!

YOU SHOULD GO BACK NOW AND STRETCH ALL ATTACHMENT HOOKS TIGHT AND DOUBLE CHECK TO SEE WHETHER YOU HAVE FASTENED THE SCREW AND BOLT OR NOT, SO THE SAFETY NET STANDS STIFF. OTHERWISE, THE SAFETY NET WILL NOT FUNCTION PROPERLY. THEN FINISH ASSEMBLING.

WARNING – GENERAL SAFETY ADVICE

- Please read the instructions before use, and retain for future reference.
- Ensure the trampoline Safety Net has been assembled correctly, as per the instructions in the manual.
- Children **MUST NEVER** use the trampoline unless supervised by a responsible adult with knowledge of trampoline use.
- Children **MUST NEVER** be left unattended inside the Safety Net at any time.
- **ALWAYS** follow the safety warnings stated with your trampoline instructions in conjunction with using Safety Net.
- **DO NOT** climb, swing or intentionally jump onto the panels or poles of the Safety Net.
- If the Safety Net material becomes damaged refrain from use.
- The Safety Net is **ONLY** intended to be used to reduce the risk of injury from falling off the trampoline.
- **DO NOT** let children take items or toys into the Safety Net.
- Please read and refer to other warnings and use information in the trampoline and Safety Net instructions before use.

Please retain this information for future reference.

Care & Use

- Assembly Information - This Safety Net must be assembled by an adult. They must be assembled exactly in accordance with the assembly instructions. Enlisting the aid of a helper will make assembly easier. This Safety Net contains small parts and is not suitable for children under 3 years old. Please take an inventory of all parts before assembly. Should there be any missing parts; the equipment must not be used until replacement parts have been fitted.
- Location – Your trampoline must be placed on a flat and level surface which is well-lighted. Under no circumstances should it be positioned on a hard surface such as concrete or asphalt, unless the ground under the trampoline has free-space of 2 metres surrounding the trampoline and is covered with a safety surface as well as a 7 metres clearance space in height. Examples of suitable surfaces are grass, sand or a play surface intended for this trampoline. It is important not to place or store anything under your trampoline. Please also read the instructions accompanied with your trampoline.

Safety Information

- This Safety Net is designed and made for family domestic use only by people 6 years and older. It is not a rebounding device. It is designed as a Safety Net to control entry and exit to and from the trampoline and allow jumpers to gain confidence, balance, coordination and agility without the fear of rebounding off the trampoline, where injury could occur.
- Adult supervision of children – Children should always be supervised while they are playing on the trampoline fitted with a Safety Net and should be instructed not to use it in an inappropriate or hazardous manner. In particular be aware of:
 - The objects children bring into the Safety Net
 - Children's activities inside the Safety Net
 - Conditions inside the Safety Net when children are using it
 - The way children get into and out of the Safety Net

- Children should not wear cycle helmets while playing on the trampoline.
- The frame of your trampoline is made of steel and it will conduct electricity. No electrical equipment (lights, heaters, extension cords, household appliances, etc.) should be permitted in or on the Safety Net under any circumstances to avoid the risk of electrocution.
- Never allow more than one person to use the trampoline at a time. Multiple users may collide with each other and this can result in serious injury.
- As your trampoline mat is raised off the ground, there is the risk of a fall when exiting the trampoline through the door of the Safety Net. Children should be assisted when entering and exiting the Safety Net so to reduce their risk of falling.
- Only the door of the trampoline Safety Net should be used to enter or exit the Safety Net.
- Weather conditions – Special care should be taken as weather conditions change. In particular, surfaces can become slippery in wet weather and tongues and lips can stick to the metalwork at subzero temperatures. In warmer and sunnier weather, parts can become hot, and temperatures should be regularly checked during use, especially metal parts.

Care & Maintenance of Your Trampoline

- With all products it is vital that the equipment is checked regularly and often by an adult. The complete products should be checked at least once a month, and particular attention should be paid to connections and fastenings. If any parts exhibit signs of wear and tear, they may need to be replaced. Failure to do this may result in the product malfunctioning and causing injury.
- The product must not be used until properly and fully installed and checked. Galvanized tubular products may require occasional maintenance. If surface rust appears it should be removed with either a wire brush or coarse sandpaper, and the area treated with non-toxic paint.
- To avoid damage to the Safety Net, do not allow pets or other animals inside. Their claws and teeth can damage the netting and the trampoline mat.
- Make sure that no bonfires are lit close enough to threaten your trampoline and Safety Net. In windy conditions, sparks and embers can travel significant distances and burn holes in both the Safety Net netting and trampoline mat.
- Any large trampoline, with or without an Safety Net, can be blown around in high winds and cause injury or damage. We recommend that the Safety Net should be removed under these conditions and stored in a dry place

USER MANUAL FOR LADDER (2 STEP/ 3 STEP)

WARNING & INSTRUCTION

- Please read the assembly instructions before beginning to assemble the product.
- Please refer to the table for part descriptions and numbers. The assembly instruction use these descriptions and numbers as reference .
- Make sure you have all parts listed. If you are missing any parts, please contact place of purchase.
- Only assemble by adult.

LADDER PART LIST

Ref.number	Part. number	Description	Unit (pcs)
1	LD001	Frame poles	2
2	LD002	Step poles	2 or 3
3	LD003	Screws	4 or 6
4	LD004	manual	1

LADDER ASSEMBLY

Step 1 . Frame install

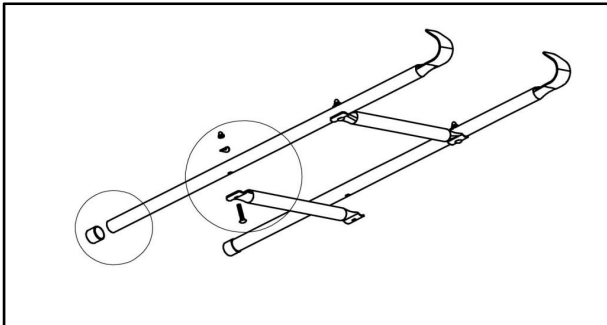

Layout all of the parts as pictures . select two frame pole which have two or three holes.

Step 2 Install screws

Pls install all of the screws use tool as show .

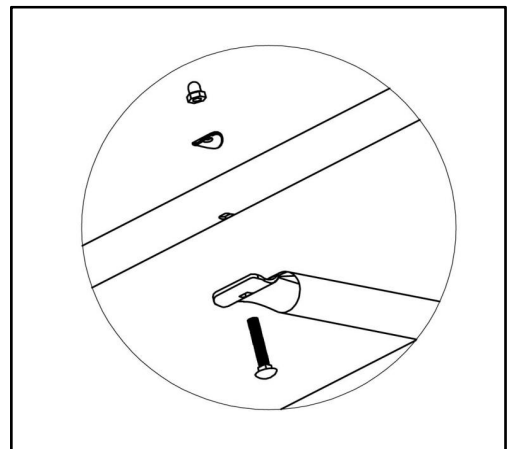
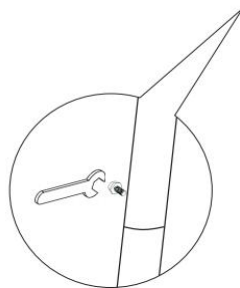

Step 3 . Install Finished

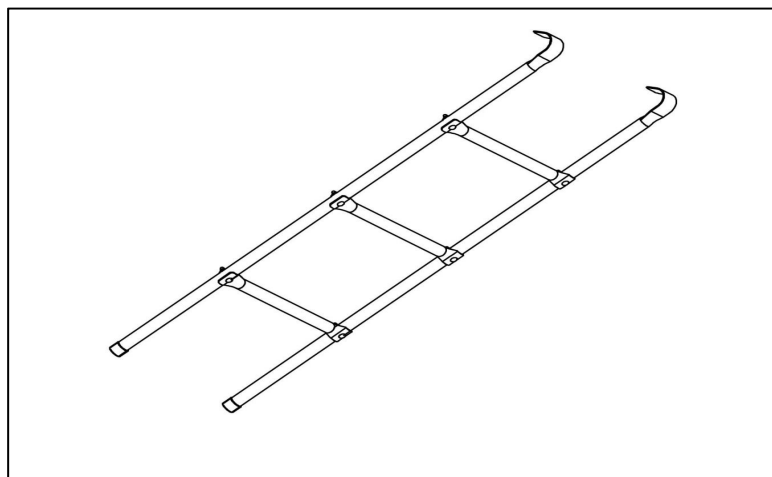

USER MANUAL

(FOR TN-TRAMPOLINE)

BASKETBALL HOOP ATTACHMENT

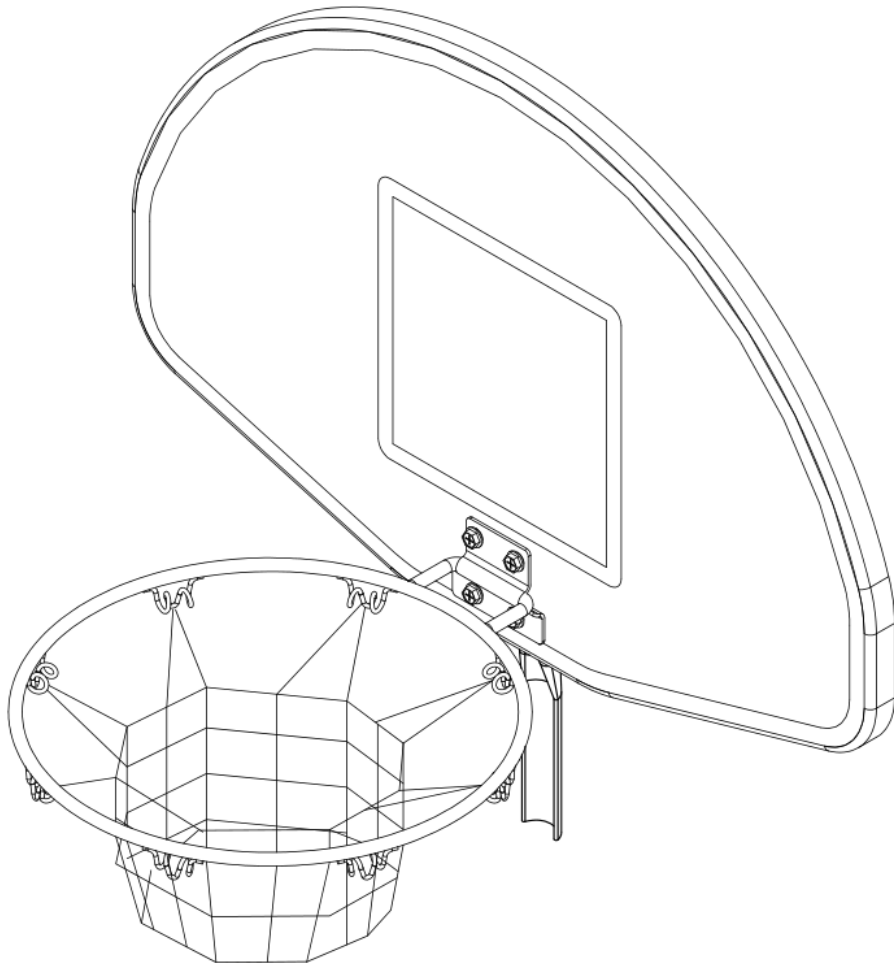







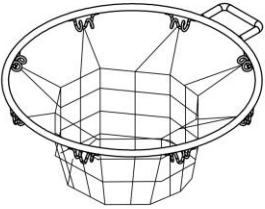
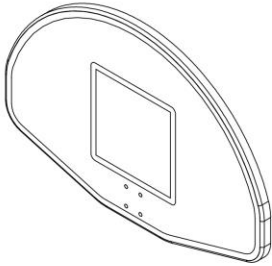
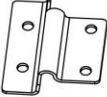
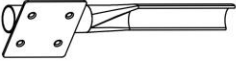

Adult Supervision

1. Adult assembly required.
2. Adult supervision required for children using basketball board.

ATTENTION:

1. Please read and follow all instructions before you use your basketball hoop attachment.
2. Please check all of the parts in the carton before you install your basketball hoop attachment.
3. Ladder is recommend to install the basketball hoop part.

Part list:

 A 1PC	 B 1PC	 C 1PC	 D 1PC
 E (M6×28) 4PCS	 F (M6×20) 2PCS	 G 1PC	 H 1PC
 I 2PC	 J 1PC	 K 1PC	

Instructions for Installation

Step 1: Assemble the hoop and bracket.

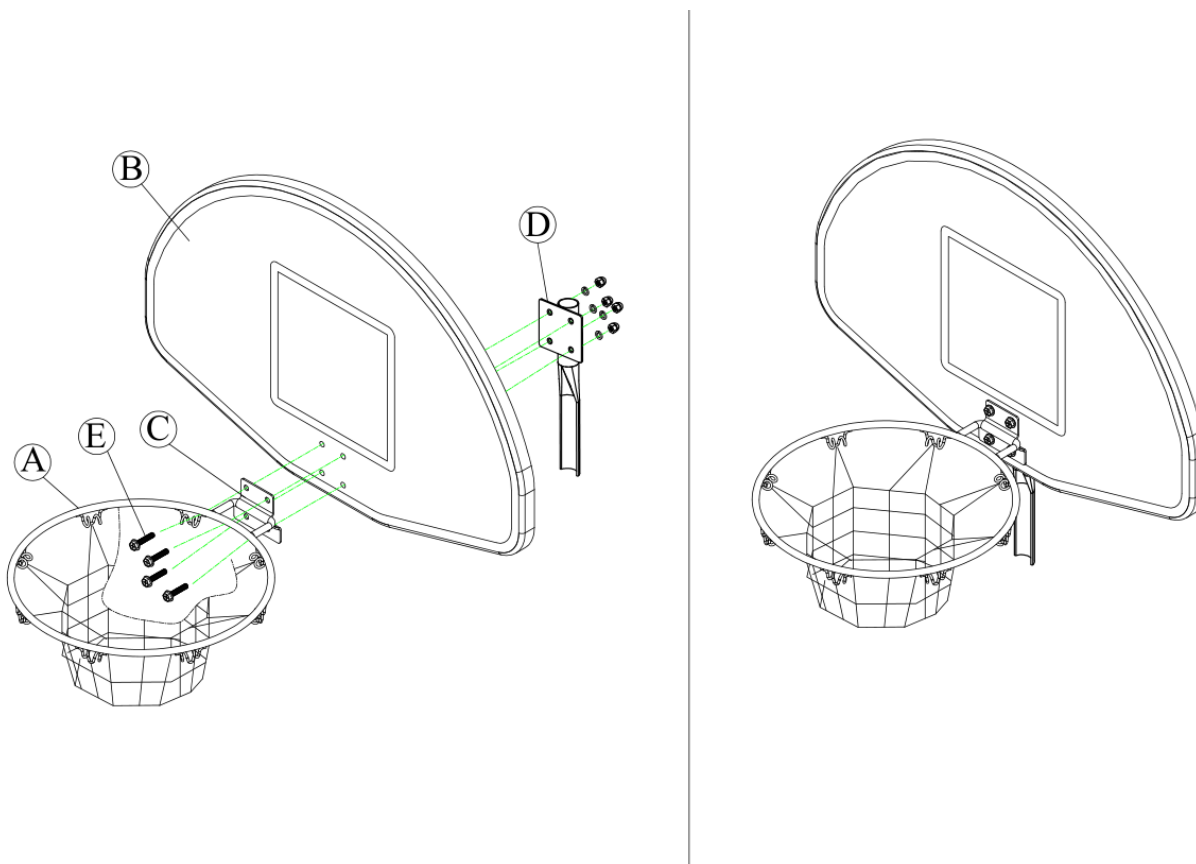

Step 2: Select an upper pole A to remove the cap, then install a flat cap

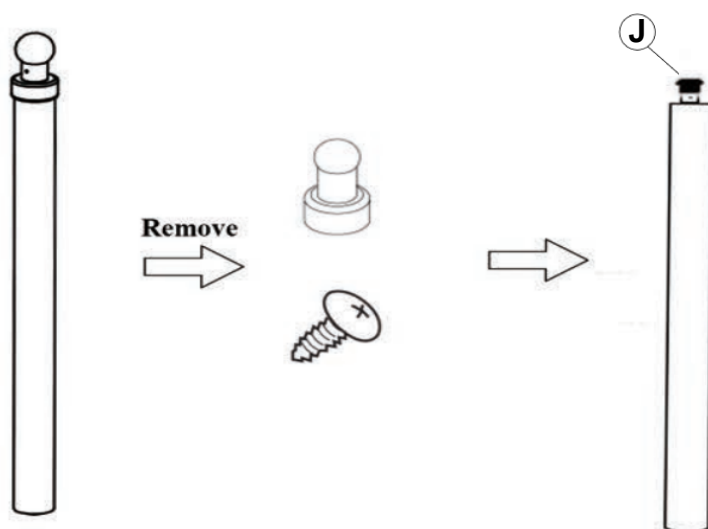

Step 3: Assemble the board on the trampoline.
(Need to remove the foam and lower the sleeve.)

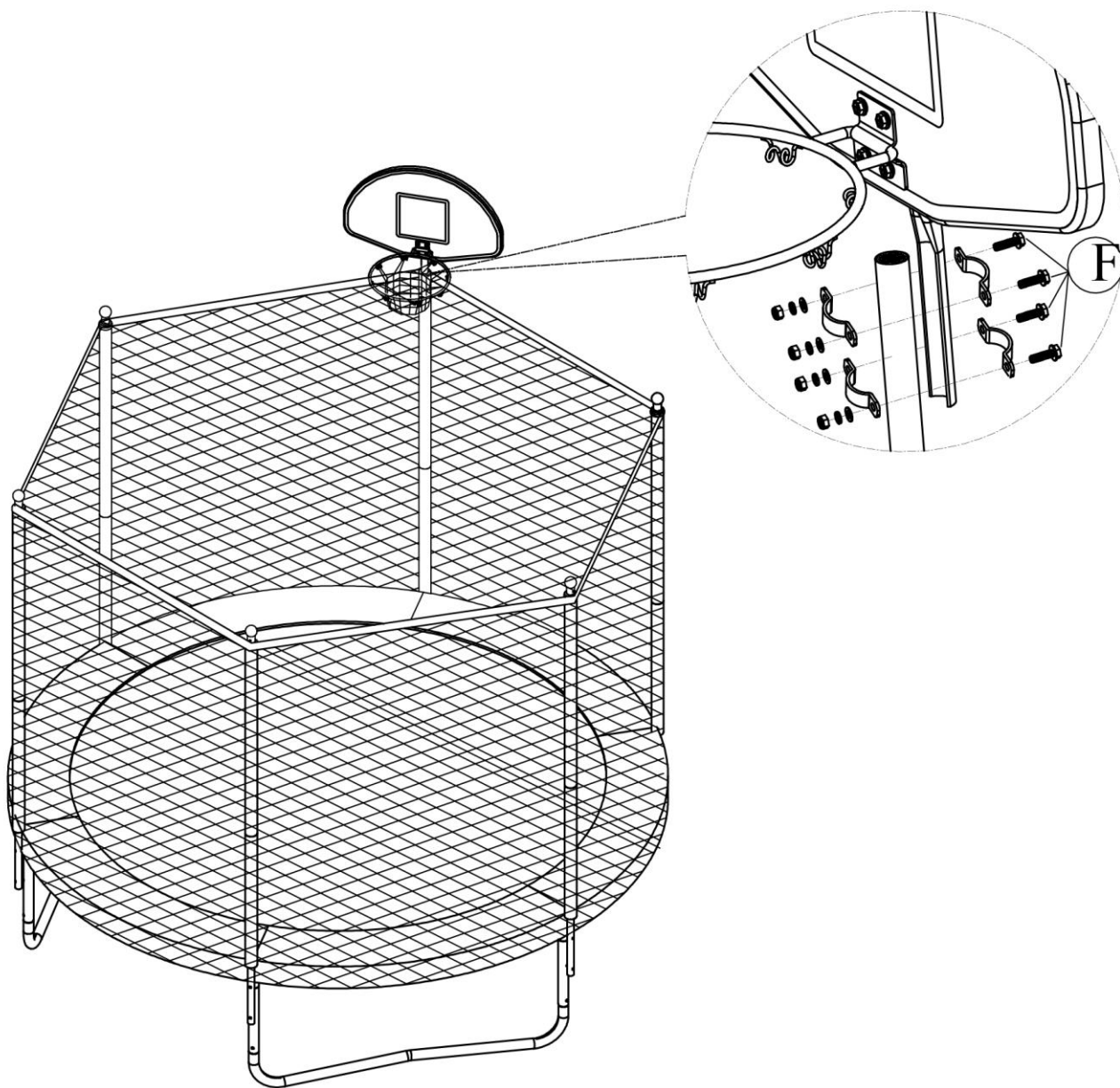

Congratulations you have successfully installed Basketball Hoop Set!